

# A Binaural I-Q Receiver



A receiver with presence... to fully appreciate this receiver, you've got to hear it!

I built this little receiver to illustrate an idea that I've been exploring for a number of years. It replaces the narrow filters and interference-fighting hardware and software of a conventional radio with a wide-open *binaural I-Q detector*. If you liken a conventional receiver to a high-powered telescope, this receiver is a pair of bright, wide-field binoculars. The receiver's classic junk-box-available-parts construction approach achieves better RF integrity than that of commercial ham gear. A PC board and parts kit is available for those who prefer to duplicate a proven design.<sup>1</sup>

My goal was a project that could be constructed in one weekend. With two working parents and three teenagers in the house, that "one weekend" wound up being spread over a period of about two months! Nevertheless, the total construction time was only 17 hours. There are a number of toroids to wind, and performance was not compromised to simplify construction or reduce parts count.

<sup>1</sup>Notes appear on page 48.

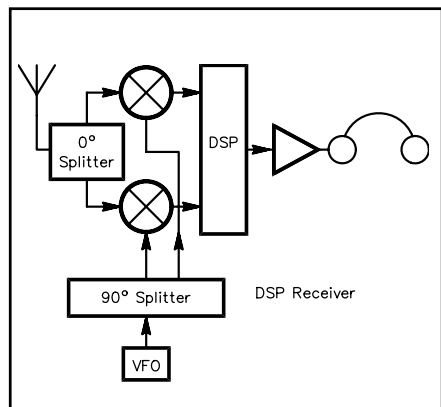

Figure 1—Simplified block diagram of a receiver using a DSP detector; see text.

## Binaural I-Q Reception

Modern receivers use a combination of band-pass filters and digital signal processing (DSP) to select a single signal that is then amplified and sent to the speaker or headphones. When DSP is used, the detector often takes the form shown in Figure 1. The incoming signal is split into two paths, then mixed with a pair of local oscillators (LOs) with a relative 90° phase shift. This results in two baseband signals: an in-phase, or *I* signal, and a quadrature, or *Q* signal. Each of the two baseband signals contains all of the information in the upper and lower sidebands. The baseband pair also contains all of the information needed to determine whether a signal is on the upper or lower sideband before multiplication. An analog signal processor consisting of a pair of audio phase-shift networks and a summer could be used to reject one sideband. In a DSP receiver, the *I* and *Q* baseband signals are digitized and the resulting sets of numbers are phase-shifted and added.

The human brain is a good processor for information presented in pairs. We have two eyes and two ears. Generally speaking, we prefer to observe with both eyes open, and listen with both ears. This gives us depth of field and three-dimensional hearing that allows us to sort out the environment around us. The ear-brain combination can be used to process the output of the I-Q detectors as shown in Figure 2.

The sound of CW signals on a binaural I-Q receiver is like listening to a stereo recording made with two identical microphones spaced about six inches apart. The same information is present on each channel, but the *relative phase* provides a stereo effect that is perceived as three-dimensional space. Signals on different sidebands—and at different frequencies—appear to originate at different points in space. Because SSB signals are

composed of many audio frequencies, they sound a little spread in the perceived three-dimensional sound space. This spreading also occurs with most sounds encountered in nature and is pleasant to hear.

To keep the receiver as simple as possible, a single-band direct-conversion (D-C) approach is used. A crystal-controlled converter can be added for operation on other bands, changing the receiver to a single-conversion superhet. Alternatively, the binaural I-Q detector can be used in a conventional superhet, with a tunable first converter and fixed-frequency BFO. If proper receiver design rules are followed, there is no advantage to either design.

## The Receiver Proper

Figures 3 through 5 show the complete schematic of the receiver. In Figure 3, signals from the antenna are connected directly to a 1 kΩ **GAIN** pot on the front panel. J1, a BNC antenna connector, is used in keeping with my "VHF construction techniques" theme. Adjusting the gain before splitting the signal path avoids the need for a two-gang volume control, and eliminates having to use separate RF and AF-gain adjustments. This volume-control arrangement leaves the "stereo background noise" constant and varies the signal-to-noise ratio. The overall gain is selected so that the volume is all the way up when the band is quiet. Resistor values R9 and R31 may be changed to modify the overall gain if required. After the volume control, the signal is split with a Wilkinson divider and connected to two SBL-1 diode-ring mixers. (The TUF-1 is a better mixer choice, but I had more SBL-1s in my junk box.) The VFO signal is fed to the two mixers through a quadrature hybrid, described by Reed Fisher.<sup>2</sup> All

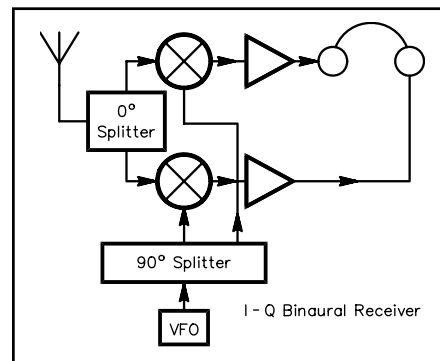

Figure 2—Block diagram of an I-Q binaural receiver that allows the ear-brain combination to process the detector output resulting in stereo-like reception.

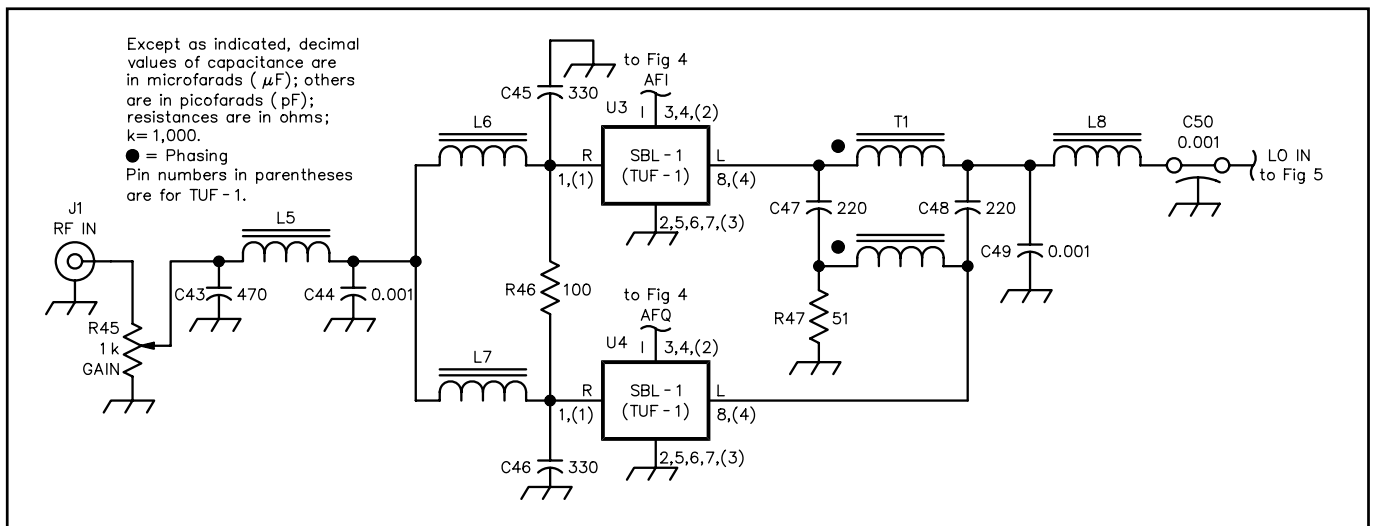

Figure 3—Front end and I and Q demodulators of the Binaural Weekender receiver. Unless otherwise specified, resistors are  $\frac{1}{4}$  W, 5% tolerance carbon-composition or film units. Equivalent parts can be substituted. Pin connections for the SBL-1 and TUF-1 mixers at U3 and U4 are shown; the TUF-1 pin numbers are in parentheses. A kit is available (see Note 1). Parts are available from several distributors including Digi-Key Corp, 701 Brooks Ave S, Thief River Falls, MN 56701-0677; tel 800-344-4539, 218-681-6674, fax 218-681-3380; <http://www.digikey.com>; Mouser Electronics, 958 N Main St, Mansfield, TX 76063; tel 800-346-6873, 817-483-4422, fax 817-483-0931; [sales@mouser.com](mailto:sales@mouser.com); <http://www.mouser.com> and Newark Electronics, 4801 N Ravenswood Ave, Chicago, IL 06040-4496; tel 800-463-9275, 312-784-5100, fax 312-907-5217; <http://www.newark.com>.

- C43—470 pF disc ceramic
- C44, C49—0.001  $\mu\text{F}$  metal polyester
- C45, C46—330 pF disc ceramic
- C47, C48—220 pF disc ceramic
- C50—0.001  $\mu\text{F}$  feed-through capacitor
- J1—Chassis-mount female BNC connector

- L5—1.6  $\mu\text{H}$ , 24 turns #28 enameled wire on T-30-6 powdered-iron core
- L6, L7—1.3  $\mu\text{H}$ , 21 turns #28 enameled wire on T-30-6 powdered-iron core
- L8—350 nH, 11 turns #28 enameled wire on T-30-6 powdered-iron core

- R45—1 k $\Omega$  panel-mount pot
- T1—17 bifilar turns #28 enameled wire on T-30-6 powdered-iron core
- U3, U4—Mini-Circuits SBL-1 or TUF-1 mixer

of the circuitry under the chassis is broadband, and there are *no* tuning adjustments.

The audio-amplifier design of Figure 4 is derived from that used in the R1 High-Performance Direct-Conversion Receiver,<sup>3</sup> with appropriate simplifications. The R1 high-power audio output is not needed to drive headphones, the low-pass filter is eliminated, and the diplexer has fewer components. Distortion performance is not compromised—well over 60 dB of in-band two-tone dynamic range is available. The original article, and the additional notes in Technical Correspondence for February 1996,<sup>4</sup> describe the audio-amplifier chain in detail.

### The VFO

Figure 5 is the schematic of the receiver's VFO, a JFET Hartley oscillator with a JFET buffer amplifier. Components for the VFO tuned circuit are chosen for linear tuning from 7.0 to 7.3 MHz with the available junk-box variable capacitor. Setting up the VFO is best done with a frequency counter, receiver and oscilloscope. The frequency counter makes it easy to select the parallel NP0 capacitors and squeezing and spreading the wire turns on L1 achieves the desired tuning range. After the tuning range is set, listen to the VFO signal with a receiver to make sure the VFO tunes smoothly and has a good note. Interrupt the power to hear its start-up chirp. The signal may sound ratty with the frequency counter on, so turn it off. The VFO is one area where craftsmanship pays off. Solid construction, a self-aligning variable-capacitor mounting, complete RF and air shielding and good capacitor bearings all contribute to a receiver

that is a joy to tune.

Both connections to the VFO compartment are made with feed-through capacitors. The power supply connection is self-explanatory, but passing RF through a feed-through capacitor (at LO Out) may seem a bit unusual. Electrically, the capacitor is one element of a low-pass pi network. Using feed-through ca-

**“Once my ears got used to the effect, they had to drag me away from this radio. This is one I gotta have!”—Ed Hare, W1RFI, ARRL Lab Supervisor**

pacitors keeps local VHF signals (high-powered FM broadcast and TV signals near my location) out of the VFO compartment. A second pi network feeds the VFO signal to the detector circuit below the chassis. The use of VHF construction techniques in a 40 meter receiver may seem like overkill, but the present KK7B location is line-of-sight to broadcast towers serving the Portland area. Using commercial HF gear with conventional bypassing under these circumstances provided disappointing results.

The accompanying photographs show the prototype receiver. Receiver controls are simple and intuitive. The ear-brain adjusts so

naturally to binaural listening that I added a **BINAURAL/MONO** switch to provide a quick reminder of how signals sound on a conventional receiver. The switch acts much like the **STEREO-MONO** switch on an FM broadcast receiver—given the choice, it always ends up in the **STEREO** position on my receiver!

The Koss SG-65 headphones identified in the parts list and shown in the photograph are not necessary, but they have some useful features. First, at \$32, they are inexpensive. Second, they have relatively high-impedance drivers, (90  $\Omega$ ) so they can be driven at reasonable volume directly from an op amp. Finally, they make an attempt at low distortion. Other headphones in the same price bracket are acceptable, but some have much lower impedance and won't provide a very loud audio signal using the component values given in the schematic. Those \$2.95 bubble-packed, throw-away headphones are *not* a good choice! Audiophile headphones are fine, but don't really belong on an experimenter's bench. A stray clip-lead brushing across the wrong wire in the circuit can instantly burn out a driver and seriously ruin your day.

### Building a Binaural Weekender

A few construction details are generally important, while others were determined by the components that happened to be in my junk box. The big reduction drive is delightful to use, but doesn't contribute to electrical performance. I purchased it at a radio flea market. The steel chassis provides a significant reduction in magnetic hum pickup, something that can be a problem if the re-

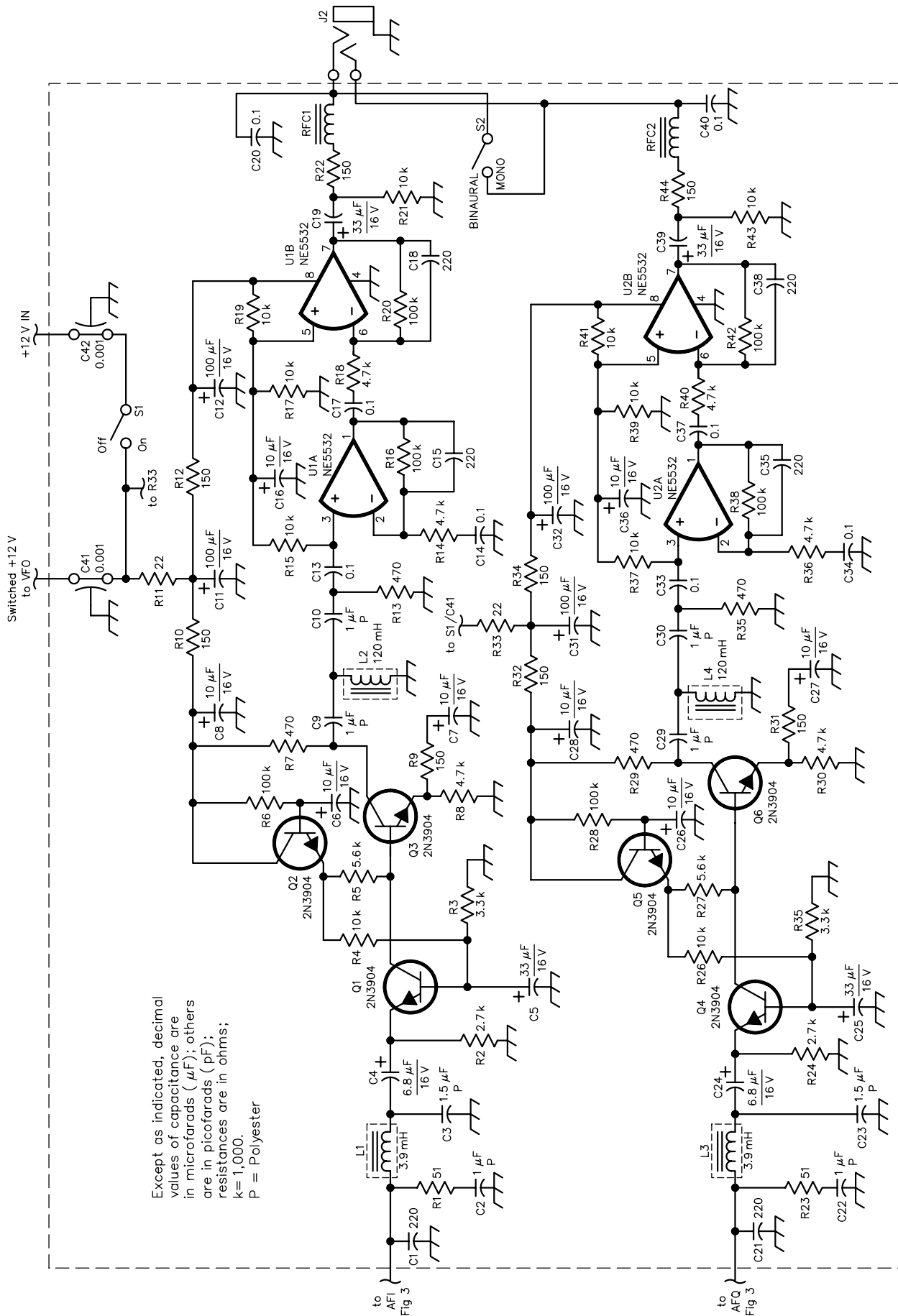

Except as indicated, decimal values of capacitance are in microfarads ( $\mu\text{F}$ ); others are in picofarads (pF); resistances are in ohms; k=1,000. P = Polyester

Figure 4—The receiver's audio-amplifier design is derived from one used in the R1 High-Performance Direct-Conversion Receiver (see Note 3), with appropriate simplifications.

C1, C15, C18, C21, C35, C38—220 pF disc ceramic  
 C2, C9, C10, C22, C29, C30—1  $\mu$ F metal polyester (Panasonic ECQ-E(F) series)  
 C3, C23—1.5  $\mu$ F metal polyester (Panasonic ECQ-E(F) series)  
 C4, C24—6.8  $\mu$ F, 16 V electrolytic (Panasonic KA series)  
 C5, C19, C25, C39—33  $\mu$ F, 16 V electrolytic (Panasonic KA series)  
 C6, C7, C8, C16, C26, C28, C27, C36—10  $\mu$ F, 16 V electrolytic (Panasonic KA series)  
 C11, C12, C31, C32—100  $\mu$ F, 16 V electrolytic (Panasonic KA series)  
 C13, C14, C17, C20, C33, C34, C37, C40—0.1  $\mu$ F metal polyester (Panasonic V series)  
 C41, C42, C50—0.001  $\mu$ F feed-through capacitor  
 J2— $\frac{1}{8}$ -inch stereo phone jack  
 L1, L3—3.9 mH Toko 10RB shielded inductor  
 L2, L4—120 mH Toko 10RB shielded inductor  
 Q1-Q6—2N3904  
 RFC1, RFC2—10 turns #28 enameled wire on Amidon ferrite bead FB 43-2401 (six-hole bead shown in photos)  
 S1, S2—SPST toggle switch  
 U1, U2—NE5532 dual low-noise high-output op amp

### What Do You Hear?

Even the earliest solid-state direct-conversion (D-C) receivers had a presence or clarity that is rarely duplicated in more elaborate receivers. Many of us remember the first time we heard this crispness in a "homebrewed" D-C receiver. As we try to "enhance" our rigs through the addition of IF filters and other "features," we still hope that the result will be as clean as that first D-C receiver.

This binaural D-C receiver is such an experience—but even better. The binaural processing supplies the ears with additional information without compromising what was already there, enhancing the presence.

As you tune through a CW signal on a quiet band (best done with your eyes closed while sitting in a solid chair), a centered signal enters, but moves to the left background, undergoes circular motions at the back of your head as you tune through zero beat, repeats the previous gyrations on the right side, fades to the right background, and finally drops away in the center. Multiple signals within the receiver passband are distributed throughout this perceived space. With training, concentration on one signal allows it to be copied among the many. An SSB signal seems to occupy parts of the space, left and right, with clarity when properly tuned, leaving others vacant. Static crashes and white noise appear distributed throughout the entire space without well defined position. Receiver noise, although present, has no perceived position.

It's vital that this receiver include a front-panel switch to shift between binaural and monaural output. Although useful during the learning process, it becomes indispensable for the demonstrations that you *will* want to do. I used the switch to set up my son, Roger, KA7EXM, for the experience. We entered the shack and I handed him the headphones. He put one phone to just one ear, but I told him that he had to use both, that it would not work with just one. He put the phones on his head, casually tuned the receiver through the 40-meter CW band, removed the phones and commented, "Well, it sounds just like a direct-conversion receiver: A good one, but still just a direct-conversion receiver." I smiled and asked him to put the headphones on again. As I flipped the switch to the binaural position his hand reached out, seeking the support of the workbench. His facial expression became more serious. He eased into the chair and began tuning the receiver, very slowly at first. After a minute he took the headphones off, but remained speechless for a while—an unusual condition for Roger. Finally, he commented, "Wow! The appliance guys have never heard that!"

A builder of the Binaural Weekender should prepare for some truly unusual experiences.— *Wes Hayward, W7ZOI*

ceiver is operated near a power transformer. (Steel chassis are available from parts houses that cater to audio experimenters.) The VFO mounting and mushroom-can shield are a simple way to eliminate mechanical backlash, keep radiated VFO energy off the antenna, prevent hand capacitance from shifting the tuning, and reduce VFO drift caused by air currents.

Experienced builders can duplicate this receiver simply using the schematic and construction techniques shown in the accompanying photographs. Unlike a phasing re-

ceiver, there is *no need* to precisely duplicate the exact amplitudes and phases between the two channels. The ear-brain combination is the ultimate adaptive processor, and it quickly learns to focus on a desired signal and ignore interference. Small errors in phase and amplitude balance are heard as slight shifts in a signal's position. Standard-tolerance components may be used throughout. A kit version is also available (see Note 1).

One note about the kit version: A very good VFO can be built on an open PC board if the variable oscillator is not running on the

desired output frequency. The Kanga kit VFO runs at one-half the desired RF frequency, and is followed by a balanced frequency doubler and driver amplifier.

### Other Experiments

My earliest experiments with binaural detectors feeding stereo audio amplifiers were done in 1979, using two antennas. The technique works very well, but requires two antennas either physically spaced some distance apart, or of different polarization. Listening to OSCAR 13 on a binaural receiver

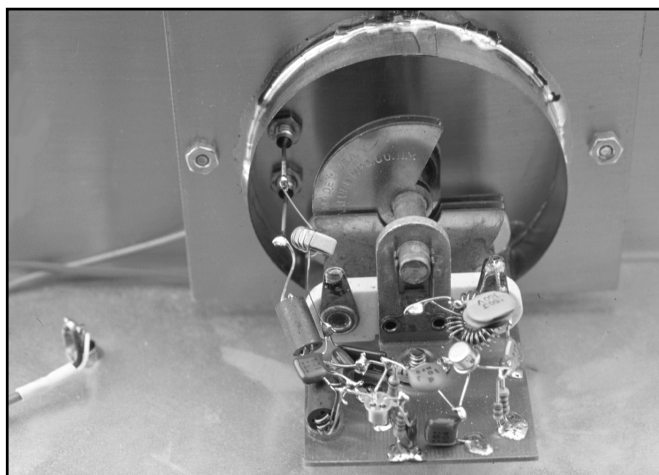

Close-up of the VFO. The simple VFO used in the prototype works exceptionally well, but must be completely shielded for good D-C receiver performance. An empty mushroom can lives again as a VFO shield.

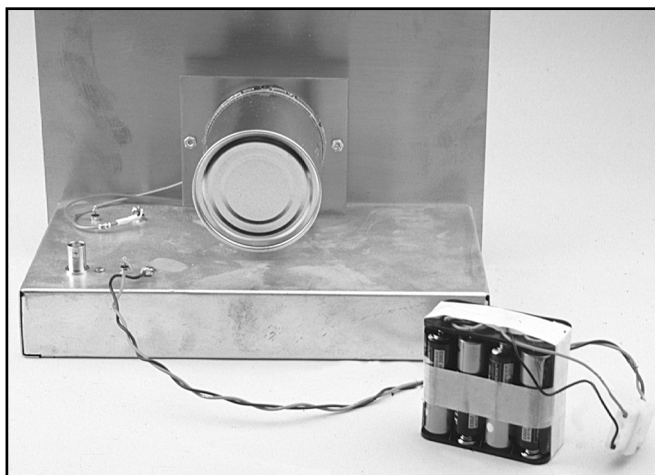
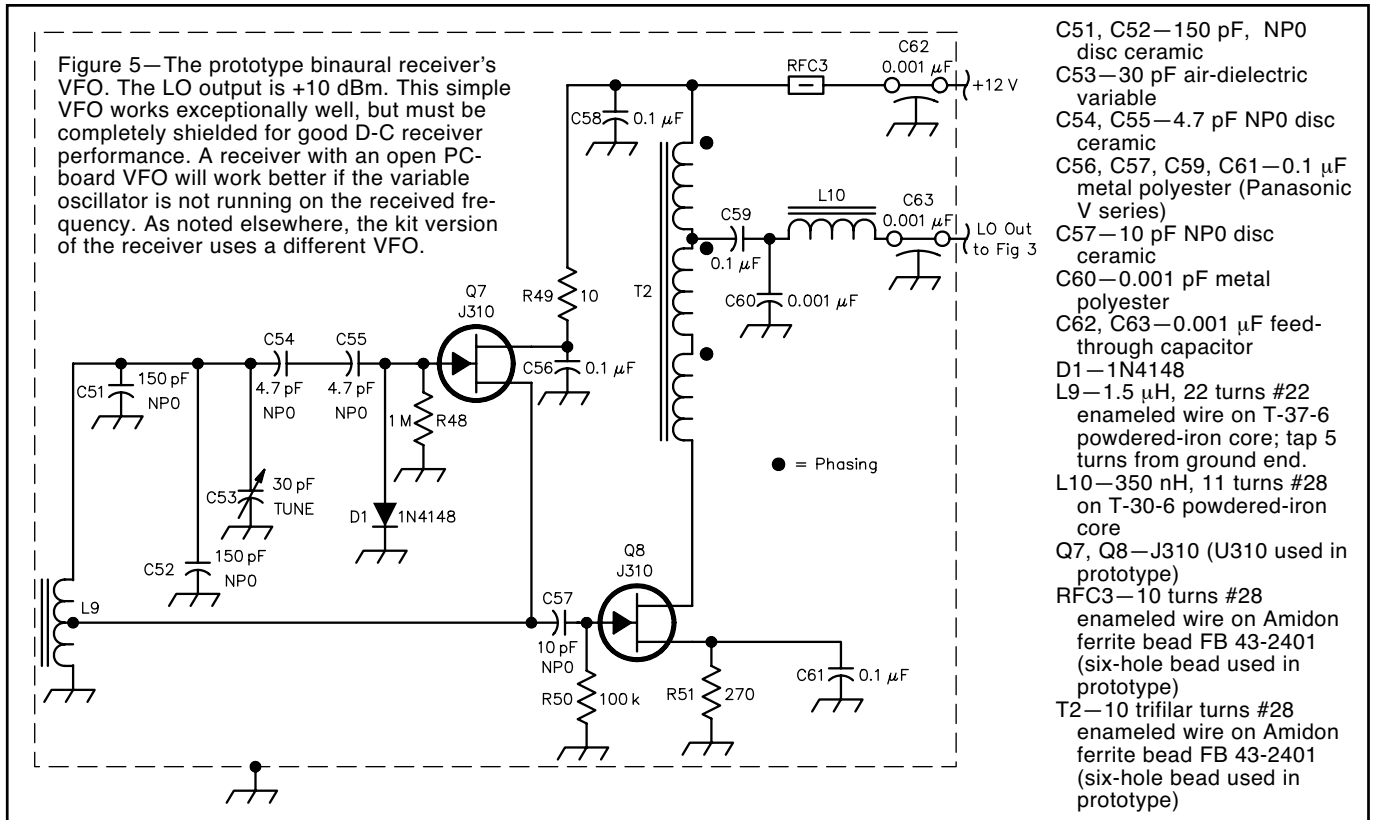

Figure 5—The prototype binaural receiver's VFO. The LO output is +10 dBm. This simple VFO works exceptionally well, but must be completely shielded for good D-C receiver performance. A receiver with an open PC-board VFO will work better if the variable oscillator is not running on the received frequency. As noted elsewhere, the kit version of the receiver uses a different VFO.



- C51, C52—150 pF, NPO disc ceramic
- C53—30 pF air-dielectric variable
- C54, C55—4.7 pF NPO disc ceramic
- C56, C57, C59, C61—0.1 μF metal polyester (Panasonic V series)
- C57—10 pF NPO disc ceramic
- C60—0.001 pF metal polyester
- C62, C63—0.001 μF feed-through capacitor
- D1—1N4148
- L9—1.5 μH, 22 turns #22 enameled wire on T-37-6 powdered-iron core; tap 5 turns from ground end.
- L10—350 nH, 11 turns #28 on T-30-6 powdered-iron core
- Q7, Q8—J310 (U310 used in prototype)
- RFC3—10 turns #28 enameled wire on Amidon ferrite bead FB 43-2401 (six-hole bead used in prototype)
- T2—10 trifilar turns #28 enameled wire on Amidon ferrite bead FB 43-2401 (six-hole bead used in prototype)

with cross-polarized Yagis was an unsettling experience. The need for two antennas is a liability—these days, most of us struggle to put up one. A number of experiments have also been done with binaural independent sideband (ISB) reception. These are profoundly interesting for AM broadcast reception, and could be used for amateur AM or DSB reception using a Costas Loop for carrier recovery. Binaural ISB detection of shortwave AM broadcasting can be analyzed as a form of spread spectrum with the ear-brain serving the despreading function, or as a form of frequency diversity, with the ear-brain as an optimal combiner.

The binaural techniques described here are analogous to binocular vision: They present the same information to each ear, but from a slightly different angle. This provides a very natural sound environment that the brain interprets as three-dimensional space. There are other “binaural” techniques that involve the use of different filter responses for the right and left ears. My experiments with different filter responses for the left and right ears have not been particularly interesting, and I have not pursued them.

### Summary

This little receiver is a joy to tune around the band. It is a serious *listening* receiver, and allows digging for weak signals in a whole new way. Digging for weak signals in a three-dimensional sound field is sometimes referred to as the “cocktail party effect.” It is difficult to quantify the performance of a binaural receiver, because the final signal processing occurs in the brain of the listener—you. The experimental lit-

erature of psycho-acoustics suggests that the ear-brain combination provides a signal-to-noise advantage of approximately 3 dB when listening to speech or a single tone in the presence of uncorrelated binaural noise. The amount of additional noise in the opposite sideband is also 3 dB, so it appears that the binaural I-Q detector breaks even. In some applications, such as UHF weak-signal work, the binaural I-Q detector may have an advantage, as it permits listening to a larger slice of the band without a noise penalty. In other situations, such as CW sweepstakes, the “cocktail party” may get entirely out of hand. Binoculars and telescopes both have their place.

### Notes

<sup>1</sup>The complete kit version, available from Kanga US, uses a different VFO circuit than the one shown here. The kit VFO runs at one-half the desired output frequency, and is followed by a balanced frequency doubler and driver amplifier. Price: Receiver and VFO PC boards with all board-mounted components, \$115 plus shipping. Contact Kanga US, Bill Kelsey, N8ET, 3521 Spring Lake Dr, Findlay, OH 45840; tel 419-423-4604; [kanga@bright.net](mailto:kanga@bright.net); <http://www.bright.net/~kangal/>.

Steel chassis such as the Hammond 1441-12 (2x7x5 inches [HWD]) with 1431-12 bottom plate and the Hammond 1441-14 (2x9x5 inches [HWD]) with 143-14 bottom plate are suitable enclosures. These chassis and bottom plates are not available in single quantities directly from Hammond, but are available from Allied Electronics, 7410 Pebble Dr, Fort Worth, TX 76118; tel 800-433-5700, <http://www.allied.avnet.com>; and Newark Electronics, 4801 N Ravenswood Ave, Chicago, IL 06040-4496; tel 800-463-9275, 312-784-5100, fax 312-907-5217; <http://www.newark.com>.

<sup>2</sup>Reed Fisher, W2CQH, “Twisted-Wire Quadrature Hybrid Directional Couplers,” *QST*, Jan 1978, pp 21-23. See also *IEEE Transactions*

*MTT*, Vol MTT-21, No. 5, May 1973, pp 355-357.

<sup>3</sup>Rick Campbell, KK7B, “High-Performance Direct-Conversion Receivers,” *QST*, Aug 1992, pp 19-28.

<sup>4</sup>Rick Campbell, KK7B, “High-Performance, Single-Signal Direct-Conversion Receivers,” *QST*, Jan 1993, pp 32-40. See also Feedback, *QST*, Apr 1993, p 75.

### References

Rick Campbell, KK7B, “Direct Conversion Receiver Noise Figure,” Technical Correspondence, *QST*, Feb 1996, pp 82-85.

Campbell, Richard L., “Adaptive Array with Binaural Processor,” *Proceedings of the IEEE Antennas and Propagation Society International Symposium*, Philadelphia, PA, Jun 1986, pp 953-956.

Rick Campbell, KK7B, “Binaural Presentation of SSB and CW Signals Received on a Pair of Antennas,” *Proceedings of the 18th Annual Conference of the Central States VHF Society*, Cedar Rapids, IA, Jul 1984, pp 27-33.

*Rick Campbell taught himself code and theory and passed the Novice test as a young teen. His early interest in radio has profoundly influenced his career. He has been a US Navy Radioman, studied surface physics at Bell Labs in the '70s, and designed direct-conversion image-reject satellite navigation receivers in the early '80s. From 1983 through 1996, he was a faculty member in Electrical Engineering at Michigan Technological University. During the early '90s, he held a summer appointment at the US Department of Commerce Institute for Telecommunications Science in Boulder, Colorado. In 1996, he left academia to join the advanced receiver development group at TriQuint Semiconductor in Hillsboro, Oregon. In addition to designing and building receivers, Rick also enjoys windsurfing, playing the violin and raising a family.*

You can contact Rick at 4105 NW Carlton Ct, Portland, OR 97229; [rickc@tqs.com](mailto:rickc@tqs.com).